

8. After-Sales

From the day you purchase our products within 3 years, if being used properly in accordance with the instruction, and quality problems occur, we provide free repair or replacement services except the following cases:

- 1.Any defects caused by wrong operations.
- 2.Any damages caused by inappropriate power supply or abnormal voltage.
- 3.Any damages caused by unauthorized removal, maintenance, modifying circuit, incorrect connections and replacing chips.
- 4.Any damages due to transportation, breaking, flooded water after the purchase.
- 5.Any damages caused by earthquake, fire, flood, lightning strike etc force majeure of natural disasters.
- 6.Any damages caused by negligence, inappropriate storing at high temperature and humidity environment or near harmful chemicals.
- 7.Product has been updated.

9. Kindly Reminder

1.Power Source Selection
Power source must be DC constant voltage type of power supply. Due to the efficient output in some power supplies are only 80% of total, so please select at least 20% higher output power supply than the consumption of LED lights.

Constant Voltage LED Power Repeater User Manual



(Please read through this manual carefully before use)

1. Brief Introduction

LED Power Repeater is suitable for all of our company's power-output style controllers' power expansion, it accepts PWM control, the control quantity of LED lights would be twice as much by adding one more power repeater, unlimited quantity of power repeater can be connected theoretically. Also, the power repeater of constant voltage model and constant current model could be connected freely, suitable for synchronized controlling on different LED lamps.

2. Specifications

Model	10A
Input voltage	DC5V-24V
Max load current	10A/CH×1
Output signal	Constant Voltage PWM
Max output power	50W(5V)120W(12V)240W(24V)
Dimension	L125×W45×H36(mm)
Package Size	L130×W47×H42(mm)
Weight (G.W)	85g

3. Basic Features

- 1.Single output channel, totally 10A.
- 2.Accept PWM control.
- 3.Unlimited connection quantity theoretically, unlimited power output expansion.
- 4.Maximum length from controller to repeater can be 500meters.
- 5.Power loss memory function.
- 6.3000V optoelectronic isolation.

4. Safety warnings

Please don't install this controller in lightening, intense magnetic and high-voltage fields.

- 1.To reduce the risk of component damage and fire caused by short circuit, make sure correct connection
- 2.Always be sure to mount this unit in an area that will allow proper ventilation to ensure a fitting temperature.
- 3.Check if the voltage and power adapter suit the controller (please select DC 12-24V power supply with constant voltage)
- 4.Don't connect cables with power on; make sure a correct connection and no short circuit checked with instrument before power on.
- 5.Please don't open controller cover and operate if problems occur.

The manual is only suitable for this model; any update is subject to change without prior notice.

5. Dimensions

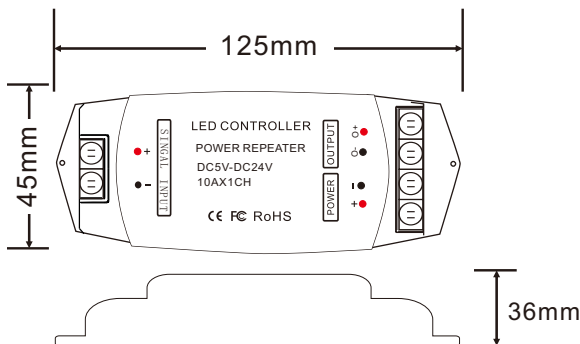

6. Conjunction Diagram

1) Repeaters connected to LED Wall Dimmer

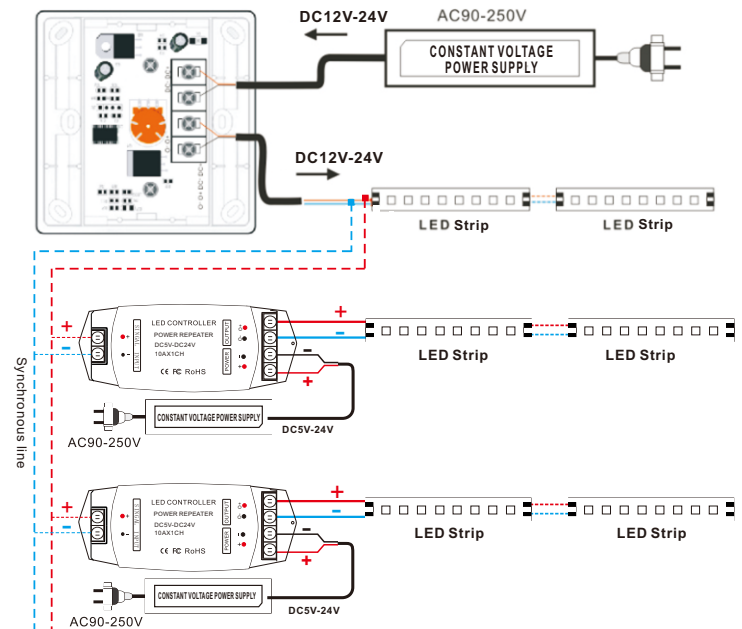

7. Exception Handles

Malfunction	Causation	Solution
No Light	1.No power from the socket 2.Reverse connection of power +/- 3. Wrong or loose connection	1.Check the socket 2.Modify the connection 3.Check connection
Brightness of the LED is not even	1.Output wire too long, voltage drops 2. Wire diameter too slim, voltage drops. 3. Power supplier overloads 4.Controller overload	1. Reduce cable or use loop connection. 2.calculate the current and change to a wider wire 3.Change to another large power supplier 4. Add a power repeater